



Product Guide 2024



PROCESS COOLING
SOLUTIONS



AIR CONDITIONING
SYSTEMS

Experience the
Best in **Heating & Cooling** Solutions

PSTHVAC.COM

WELCOME

Pars Sanat Tahviah co.

Welcome to PST HVAC Solutions

At PST, we take pride in providing the best HVAC solutions for industrial, commercial, and residential environments. With years of experience and the use of cutting-edge technology, our products are designed to deliver the best performance, efficiency, and comfort for you.

Our Products:

Residential and Commercial Chillers:

- ▶ High efficiency and optimized energy consumption
- ▶ Robust design and long lifespan
- ▶ Silent and reliable operation

Process Cooling System :

- Ideal for large and commercial buildings
- Smart systems with temperature and humidity control
- Easy installation and maintenance.

Fan Coil Units and Air Handlers:

- Suitable for residential and office environments
- Elegant and quiet design
- Precise temperature control capabilities

Our Mission:

At PST, our mission is to provide the best HVAC solutions to create comfortable, healthy, and efficient environments for all our customers. By focusing on innovation, quality, and customer satisfaction, we strive to be your top choice always.

Why Choose PST?

● **Expertise and Experience:** With over 20 years in the HVAC industry, we lead the way in offering innovative and efficient solutions for our customers.

● **Superior Quality:** Our products are manufactured using the best materials and the latest technologies to ensure the highest level of quality and durability.

● **Excellent Support:** Our support team is ready to provide consultation, installation, and maintenance services, ensuring we are always by your side.

AIR HANDLING UNITS

Pars Sanat Tahviah co.

Air Handling Units (AHUs): Comprehensive Climate Control Solutions

Our AHUs are engineered to provide precise and efficient climate control for a wide range of applications, ensuring optimal air quality and comfort in residential, commercial, and industrial environments. Explore the features, benefits, and applications of our high-quality Air Handling Units.

Air Handling Units (AHUs) are essential components of HVAC systems that condition and circulate air within buildings. They typically include components such as fans, filters, heating/cooling coils, humidifiers, and dampers. AHUs are designed to control temperature, humidity, and air quality, making them crucial for maintaining a comfortable and healthy indoor environment.

What are Air Handling Units?

Benefits of Our Air Handling Units

1.Enhanced Air Quality:

- Our AHUs are equipped with advanced filtration systems that remove dust, pollen, and other airborne contaminants, ensuring clean and healthy indoor air.

2.Energy Efficiency:

- Designed to optimize energy use, our AHUs help reduce operational costs while maintaining consistent performance and comfort levels.

3.Customizable Solutions:

- We offer a range of AHU models with customizable features to meet the specific requirements of different environments and applications.

4.Reliable Performance:

- Built with high-quality materials and components, our AHUs deliver reliable and long-lasting performance, minimizing downtime and maintenance costs.

5.Quiet Operation:

- Engineered for low noise levels, our AHUs ensure a quiet and comfortable indoor environment, ideal for both residential and commercial spaces.

Types of Air Handling Units

Compact Air Handling Units

Modular Air Handling Units

Features:

- ✓ Flexible design for easy customization
- ✓ High-efficiency components for energy savings
- ✓ Suitable for a wide range of applications

Application:

- ✓ Office buildings
- ✓ Shopping malls
- ✓ Hospitals

Standard Rooftop Units

Features:

- ✓ Space-saving design for limited spaces
- ✓ Quiet and efficient operation
- ✓ Ideal for smaller commercial and residential applications

Application:

- ✓ Apartments
- ✓ Small offices
- ✓ Retail stores

Rooftop Air Handling Units

Packaged Rooftop Units

Rooftop Air Handling Units

Features:

- ✓ Designed for outdoor installation on rooftops
- ✓ Weather-resistant construction
- ✓ High capacity for large commercial and industrial buildings

Application:

- ✓ Factories
- ✓ Warehouses
- ✓ Large office complexes

Hygienic Air Handling Units

Features:

- ✓ Specialized design for environments with strict hygiene requirements
- ✓ Easy to clean and maintain
- ✓ Advanced filtration and sterilization options

Application:

- ✓ Hospitals
- ✓ Clean rooms
- ✓ Pharmaceutical facilities

Applications of Air Handling Units

Residential:

- Our AHUs ensure optimal air quality and comfort for homes and apartments, providing efficient heating, cooling, and ventilation.

Commercial:

- Ideal for office buildings, hotels, shopping centers, and restaurants, our AHUs offer reliable climate control solutions that enhance comfort and productivity.

Industrial:

- In industrial settings, our AHUs provide robust and efficient climate control for factories, warehouses, and other large facilities, ensuring a safe and comfortable working environment.

Healthcare:

- Our AHUs are perfect for healthcare facilities such as hospitals and clinics, where precise temperature, humidity control, and air quality are critical for patient care and safety.



PROCESS COOLING
SOLUTIONS

Pars Sanat Tahviah co.



AIR CONDITIONING
SYSTEMS

AIR HANDLING UNITS

Cooling capacity 50-250 kW



PST AHU		width (mm)							
		1020	1325	1630	1935	2220	2670	3300	4000
Height (mm)	1045	4000	5100-6000						
	1225		6800-7600						
	1555		8500-11000	11900-14500	15300-17800				
	1845				18700-21200				
	2145				22000-25500				
	2230					26500-30500	31500-37500	38000-47000	
	2850							47500-63000	63500-68000

- * max. velocity on coils is 2.5 m/s
- * Airflow unit is m3/h
- * AHUs with larger sizes can be provided

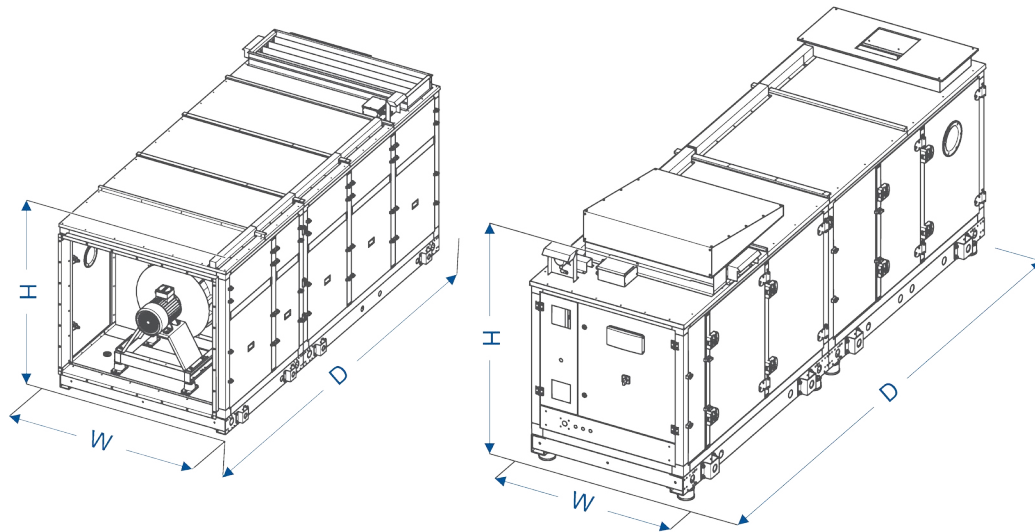

PST

Pars Sanat Tahviah co.



Website: www.psthvac.com

Email: info@psthvac.com



Phone: 021 26 76 37 10

Fax: 021 26 76 37 22



Flat NO.1,NO 36, Moqaddas st, (11 West) South Shahr-dari
Blvd Gheysar Amin pour, Sq Saadat Abad, Tehran-Iran



Kar Blvd.,Soleman Sabahi Indutrial Town,Kashan-Iran

UN

FI